

canfield connector
8510 Foxwood Court
Youngstown, Ohio 44514
(330) 758-8299 Fax: (330) 758-8912
www.canfieldconnector.com

SERIES 7000 INSTALLATION GUIDE

**Standard Cable Module (9ft)
Style 0**

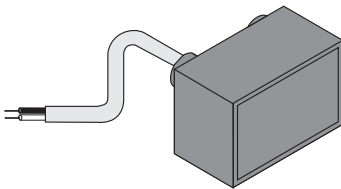

**12mm Quick Connect
Style 5**

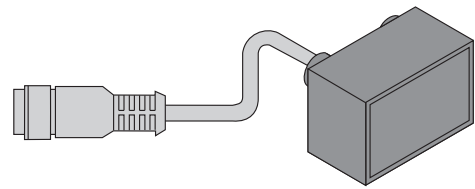

(switches shown above with no clamps)

Installation Instructions

1. Connect Reed Switch to the cylinder as shown below, according to proper clamp style.
Hand tighten clamp only, allowing adjustment of sensor position on cylinder.
2. Connect wiring as per enclosed diagram.
3. While operating cylinder, adjust sensor to desired position. Firmly secure clamp assembly, once desired results are achieved.

Installation Tips

1. Current & voltage demands of the load must NOT exceed the current & voltage ratings of the selected switch (shown on the enclosed wiring diagram). Failure to use proper load will ruin the switch. For DC voltages, always observe polarity.
2. Two wire versions can NOT be connected directly across the power supply without a series load. Failure to use a series load will damage the switch and possibly the power supply.
3. Never test switch with a filament light bulb as a load. Severe inrush currents will impair the switch or cause premature failure.
4. There are three types of loads: Resistive (PC or PLC), Capacitive (long wire runs), Inductive (solenoids)
5. The shorter the wire runs, the lower the capacitive load and the longer the switch life.
6. Always keep the area around the switch clean and free from potentially magnetic field-carrying debris. The switches actuate on magnetic fields produced from the cylinder position. Stray magnetism can give unwanted switch actuation or change the switch point.
7. When using the switch to actuate a solenoid, always use a surge suppression version and/or Canfield MPC solenoid valve surge suppression connector. Without surge suppression, large inductive spikes can severely limit switch life expectancy.
8. Use the switch to indicate end of physical stroke. Do not rely on switch alone to stop cylinder travel.
9. Be sure the sensing area of the switch is installed completely against the cylinder wall.
10. Some Reed and Electronic switches are equipped with indicator lights. Their light always depicts the on state of the switch. On these versions, the two wire hook-up necessitates a minimum load current rating which must be enough to light the LED (@ 0.005 Amps). Three wire versions take no minimum load current rating to light the LED.

Clamp Styles

(Mix and match with switch styles)

Universal 2" to 6" Bore NFFPA Tie Rod

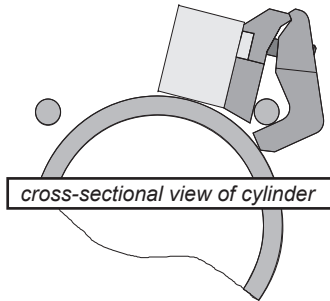

Shown on 1/2" Conduit Switch

6" to 8" Bore NFFPA Tie Rod

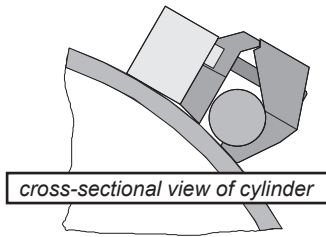

Shown on Standard Switch

3/4" to 4" Round Cylinder

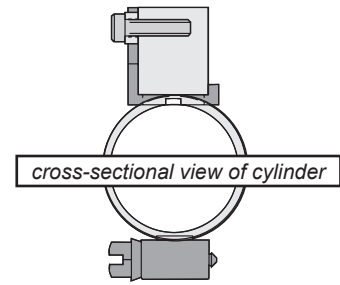

Shown on Standard Switch

Clamp Style Kits:

710-200-000 = 3/4" to 1 3/4" O.D. Round Cylinder Bracket and Clamp
 710-300-000 = 1 9/16" to 2 1/2" O.D. Round Cylinder Bracket and Clamp
 710-400-000 = 2 5/16" to 3 1/4" O.D. Round Cylinder Bracket and Clamp
 710-500-000 = 3 1/16" to 4" O.D. Round Cylinder Bracket and Clamp

Mechanical Installation

Universal clamp, both Hall & Reed devices

#8-32 SH Stainless cap screw

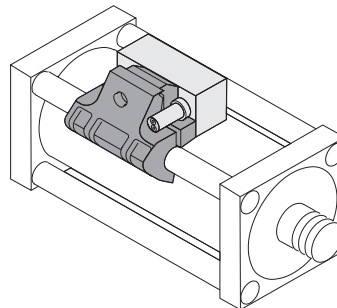
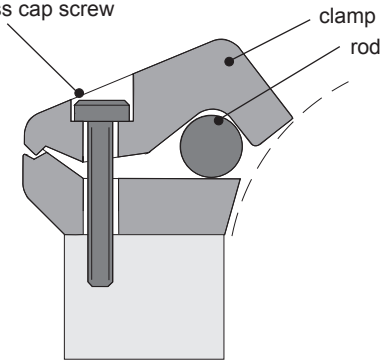

9/64" Allen wrench

Recommended torque
6 - 10 in lbs

Fits 2" to 6" bore cylinders

Do Not Exceed
25 in lbs torque

Do not over tighten clamping
screw as damage could
result to the switch.

Universal Clamp for Round Cylinders

Hose clamp must be invisible to magnetism.
Use marine grade 300 series stainless clamps only.

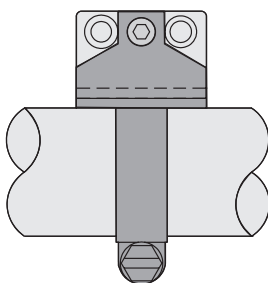

Do not over tighten hose clamp. Max. torque 3 ft lbs.

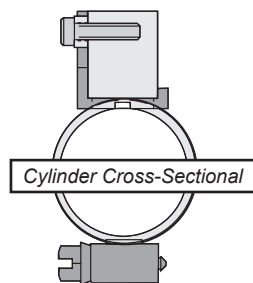

WARNING: Do not use in life or limb threatening applications. Severe injury could result.

Test the switches on your cylinder first as the switch has designed to be used well within the magnetic gauss ratings of most cylinder manufacturers. Note also that Electronic magnets and Reed magnets differ. The magnetic poles are perpendicular to each other. This could double actuate should a reed magnet be used on a Electronic switch and vice versa.

SERIES 7000 TYPE 01, 04, 05, 06, 08, 09, 11, 12, 15, 16, 21, 23, 24, 25, 29, 31 & 32

Wiring Diagram

Type 01 & 05

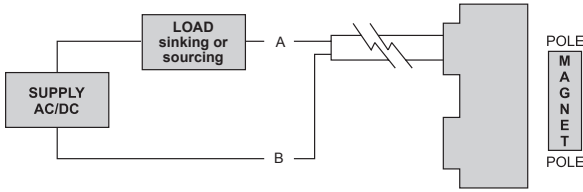

Type 04, 08 & 09

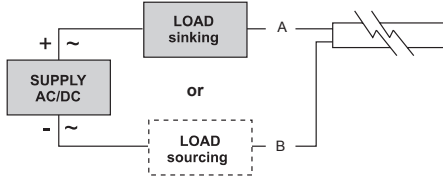

9' Wired Style

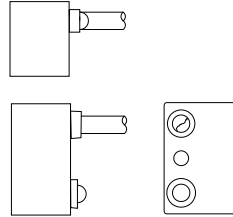

12mm Male Quick Connector Style

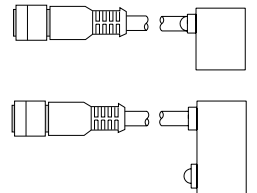

Type 06

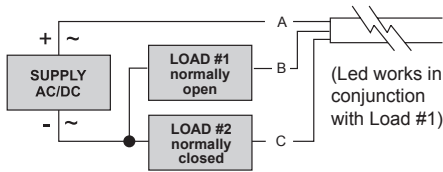

Gauss Rating: 85 - Minimum Gauss rating required for proper operation as measured on sensor surface.

*Wired Style
**Connector Style

	9' Wired Style	12mm Male Quick Connector Style
A	RED	Pin 1 (BRN)
B	BLK	Pin 3 (BLU)
C	WHT	Pin 4 (BLK)

Type 15 & 16

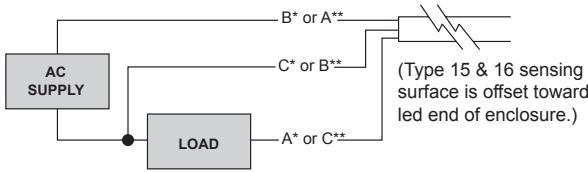

Type 21 & 25

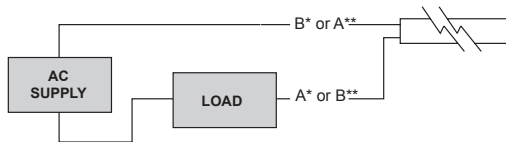

Type 23, 24 & 29

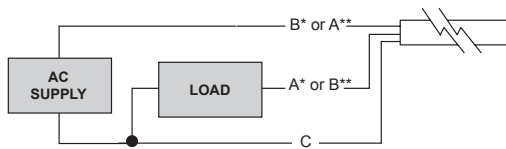

Type 31 & 11 (40 Gauss perpendicular)

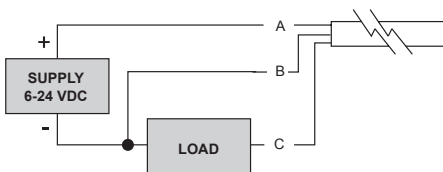

Type 32 & 12 (40 Gauss perpendicular)

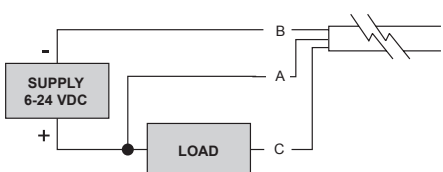

Type	Description	Function	Switching Voltage	Switching Current	Switching Power	Switching Speed	Voltage Drop
01	Reed Switch, 2 Wire	Normally Open SPST	0 - 240V AC/DC 50/60 Hz	1 Amp max.	30 Watts max.	0.6 ms operate 0.05 ms release	0 Volts
04	Reed Switch, MOV, LED, 2 Wire	Normally Open SPST	5 - 240V AC/DC 50/60 Hz	1 Amp max. .005 Amps min.	30 Watts max.	0.6 ms operate 0.05 ms release	3 Volts
05	Reed Switch, 2 Wire	Normally Closed SPST	0 - 120V AC/DC 50/60 Hz	1 Amp max.	20 Watts max.	1.0 ms operate 0.02 ms release	0 Volts
06	Reed Switch, LED, 3 Wire	Single Pole, Double Throw	5 - 120V AC/DC 50/60 Hz	1 Amp max. .005 Amps min.	20 Watts max.	1.0 ms operate 0.02 ms release	3Volts/load1 0Volts/load2
08	Offset Reed Switch, MOV, LED, 2 Wire	Normally Open SPST	5 - 120V AC/DC 50/60 Hz	.25 Amp max. .005 Amps min.	10 Watts max.	0.6 ms operate 0.05 ms release	3 Volts
09	Reed Switch, MOV, LED, 2 Wire	Normally Closed SPST	5 - 120V AC/DC 50/60 Hz	1 Amp max. .005 Amps min.	20 Watts max.	1.0 ms operate 0.02 ms release	3 Volts
11	Electronic for Reed Magnet, LED & Sourcing, 3 Wire	Normally Open PNP	6 - 24 VDC	1 Amp max.	24 Watts max.	1.5 µs operate 0.5 µs release	0.5 Volts
12	Electronic for Reed Magnet, LED & Sinking, 3 Wire	Normally Open NPN	6 - 24 VDC	1 Amp max.	24 Watts max.	1.5 µs operate 0.5 µs release	0.5 Volts
15	AC Electronic Sensor for Reed Magnets, LED, 3 Wire	Normally Open TRIAC output	12-24 VAC	600 mA max. 5 Amps Inrush	15 Watts max.	1.5 µs operate 0.5 µs release	1 Volt
16	AC Electronic Sensor for Reed Magnets, LED, 3 Wire	Normally Open TRIAC output	120 VAC	600 mA max. 5 Amps Inrush	72 Watts max.	1.5 µs operate 0.5 µs release	1 Volt
21	Reed Switch, MOV, LED, 3 Wire	Normally Open TRIAC output	10 - 240 VAC 50/60 Hz	4 Amps max. 50 Amps Inrush	100 Watts max.	0.6 ms operate 0.05 ms release	1 Volt
23	Reed Switch, MOV, LED, 3 Wire	Normally Open TRIAC output	10 - 50 VAC 50/60 Hz	4 Amps max. 50 Amps Inrush .005 Amps min.	100 Watts max.	0.6 ms operate 0.05 ms release	1 Volt
24	Reed Switch, MOV, LED, 3 Wire	Normally Open TRIAC output	24 - 240 VAC 50/60 Hz	4 Amps max. 50 Amps Inrush .005 Amps min.	100 Watts max.	0.6 ms operate 0.05 ms release	1 Volt
25	Reed Switch, MOV, 2 Wire	Normally Closed TRIAC output	10-120 VAC 50/60 Hz	4 Amps max. 50 Amps Inrush	100 Watts max.	0.6 ms operate 0.05 ms release	1 Volt
29	Reed Switch, MOV, LED, 3 Wire	Normally Closed TRIAC Output	10-120 VAC 50/60 Hz	4 Amps max. 50 Amps Inrush .005 Amps min.	100 Watts max.	0.6 ms operate 0.05 ms release	1 Volts
31	Electronic for Reed Magnet, LED & Sourcing, 3 Wire	Normally Open PNP	6 - 24 VDC	1 Amp max.	24 Watts max.	1.5 µs operate 0.5 µs release	0.5 Volts
32	Electronic for Reed Magnet, LED & Sinking, 3 Wire	Normally Open NPN	6 - 24 VDC	1 Amp max.	24 Watts max.	1.5 µs operate 0.5 µs release	0.5 Volts

WARNING! - Do not exceed maximum rating or incorrect wiring hook-up which will result in damage to switch.

Trouble Shooting Notes:

Problem

Solution

Reed Switch Models

Reed Switch works but LED does not light

1. Check current draw of load. It must be > 5 mA for LED to light.
2. Check polarity: Refer to wiring diagram if using DC power supply.

Reed switch sticks in closed position.

1. Check current draw, power/VA and voltage of load and compare with specs of the appropriate model sensor. These can not be exceeded.
2. Voltage/Current spikes may be excessive for your particular load. External transient suppression may be required.
3. Long wire runs (greater than 25') can cause capacitance build-up and sticking will result. Consult factory for solution.

Current or voltage leakage when reed switch is off.

1. Check current, power/VA and voltage rating of load and compare with specs of appropriate model sensor. Those can not be exceeded.
2. Reed element was damaged. Consult factory.

Reed switch will not turn on.

1. Check magnet strength on surface of sensor. It must be >85 Gauss.
2. Switch is damaged. Consult factory.
3. Check for proper wiring.

Reed switch turns on more than once as magnet passes beneath it.

1. Check for proper magnet polarity. The poles must be parallel to the switch as shown in the wiring diagram.
2. Check for dead spots on the magnet if polarity is correct.

Electronic Models

Electronic switch always stays on.

1. Power supply exceeds 24 VDC. Regulate if possible.
2. Switch is wired incorrectly. Check wiring diagram.
3. Switch was damaged possibly by transients, or excessive current draw. Consult factory.

Electronic switch will not turn on.

1. Check magnet strength on surface of sensor. Check chart for sensitivity.
2. Check for proper wiring.
3. Switch is damaged. Consult factory.

Electronic switch turns on more than once as magnet passes beneath it.

1. Check polarity of the magnet. The poles should be oriented as shown in the wiring diagram.
2. Check for dead spots on the magnet if polarity is correct.

Current or voltage leakage when Electronic switch is off.

1. Check current, and voltage rating of load and compare with specs of appropriate model sensor. Those can not be exceeded.
2. Check for proper wiring.
3. Electronic element was damaged. Consult factory.

1 year warranty

All products manufactured by Canfield Connector are warranted by Canfield Connector to be free of defects in material and workmanship for a period of one year from the purchase date. Canfield Connector's obligation under this warranty is limited to repair or replacement of the defective product or refund of the purchase price paid solely at the discretion of Canfield Connector and provided such defective product is returned to Canfield Connector freight prepaid and upon examination by Canfield Connector such product is found defective. This warranty shall be void in the event that product has been subject to misuse, misapplication, improper maintenance, or tampering. This warranty is expressed in lieu of all other warranties, expressed or implied from Canfield Connector representatives or employees.